

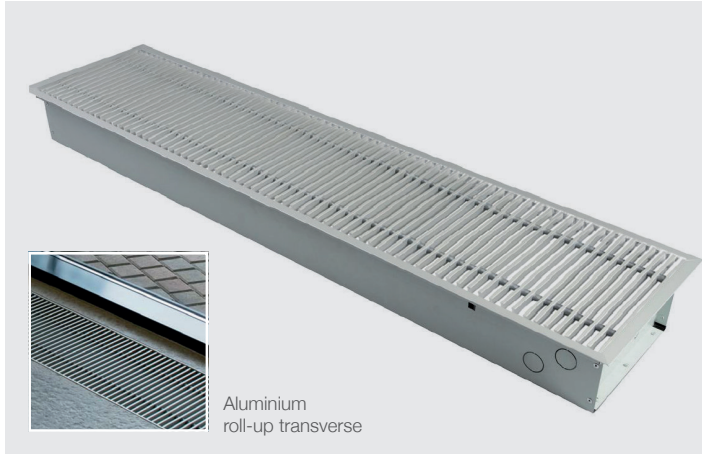

# PTHF-250

- > Trench Heater (250 mm Wide)
- > Low Energy Consumption
- > 24 V DC EC Fan



Aluminium roll-up transverse

## DESCRIPTION

Designed to provide heating in areas with large glass walls, for either commercial or domestic applications with lengths from 700 mm to 4800 mm.

### Fixing:

- floor installation
- adjustable fixing feet
- connects to LTHW systems

## WORKING CONDITIONS

Max. temperature 110°C  
 Max. overpressure 1 MPa (10 bar)  
 Protection IP 20

**Ambient conditions:** Temp. T = +2 to +40°C, Humidity Rh = 20 to 70%

## NOTES

All dimensions are given in mm. PTF-250/65 is only available with aluminium low transverse grilles. Extension pieces and valves are available on request.

## CONSTRUCTION

### Construction:

Galvanised steel trough with black powder coating interior. Anodised aluminium ledge.

### Grilles:

Anodised aluminium, wood, stainless steel.

### Options:

- 'J' Ledge (standard) with a choice of colours
- 'L' Ledge overlapped flange with a choice of colours

## GRILLE MATERIALS

### Transverse roll up:

- Aluminium (no finish, bronze or black)
- Stainless Steel
- Oak (natural or stained)
- Beech (natural or stained)

### Linear-non rolling:

- Aluminium (none, bronze or black)

## MODELS

- PTF-250/65:** 65 mm depth (2 pass)  
**PTF-250/80:** 80 mm depth (2 pass)  
**PTF-250/90:** 90 mm depth (4 pass)  
**PTF-250/110:** 110 mm depth (4 pass)  
**PTF-250/125:** 125 mm depth (4 pass)  
**PTF-250/140:** 140 mm depth (4 pass)

DIMENSIONS (mm)						
Model	65	80	90	110	125	140
A	N/A	N/A	27	41	41	41
B	43	43	42	45	60	75
C	34	35	44	45	45	45
D	38	38	28	28	28	28
E	44	56	64	84	99	114
F	38	48	43	48	48	48
G	N/A	N/A	29	39	39	39
H	43	43	40	48	63	78
J	50	50	38	42	42	42
K	60	60	88	86	86	86

## PTHF-250/90 (4 pass)

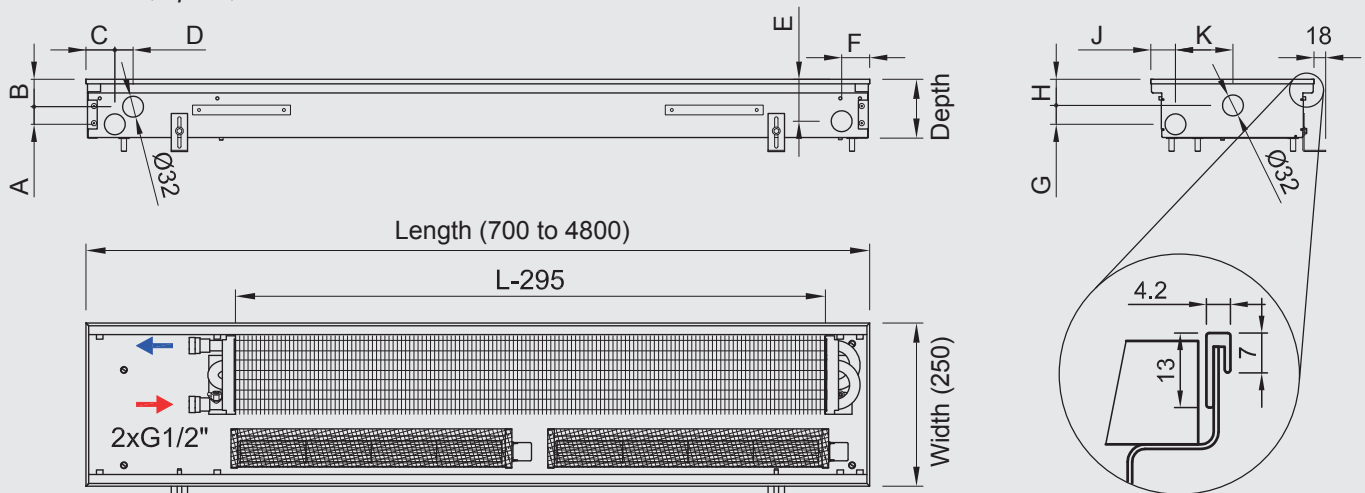

# PTHF-250 – SELECTION DATA

Q[W] 75/65/20°C (ΔT=50°C)		SPEED [-] / HEATING OUTPUT [W]											
		250/65		250/80		250/90		250/110		250/125		250/140	
		min	max	min	max	min	max	min	max	min	max	min	max
Lengths (mm)	700	149	469	163	535	253	752	288	851	298	886	311	928
	900	238	750	262	857	404	1204	461	1362	476	1417	497	1484
	1200	396	1249	436	1428	674	2006	768	2271	794	2362	828	2474
	1500	535	1687	588	1927	910	2708	1037	3065	1072	3189	1118	3340
	1800	674	2124	741	2427	1146	3410	1306	3860	1350	4016	1408	4206
	2100	824	2596	906	2966	1395	4152	1590	4700	1644	4890	1714	5121
	2400	923	2908	1015	3323	1564	4654	1782	5268	1842	5481	1922	5740
	3000	1172	3692	1288	4218	1982	5897	2259	6676	2335	6945	2435	7274
	3600	1509	4754	1659	5432	2555	7602	2912	8606	3010	8953	3139	9377
	4200	1757	5538	1932	6328	2973	8846	3388	10013	3502	10418	3653	10911
4800	1995	6288	2194	7184	3377	10049	3849	11376	3979	11835	4149	12395	

Q[W] 55/45/20°C (ΔT=30°C)		SPEED [-] / HEATING OUTPUT [W]											
		250/65		250/80		250/90		250/110		250/125		250/140	
		min	max	min	max	min	max	min	max	min	max	min	max
Lengths (mm)	700	85	267	93	305	144	429	164	485	170	505	177	529
	900	136	428	149	489	230	686	263	777	271	808	283	846
	1200	226	712	249	814	384	1144	438	1295	453	1347	472	1410
	1500	305	962	335	1099	519	1544	591	1747	611	1818	637	1904
	1800	384	1211	422	1384	653	1944	745	2201	770	2290	803	2398
	2100	470	1480	517	1691	795	2367	906	2680	937	2788	977	2920
	2400	526	1658	579	1895	892	2653	1016	3003	1050	3125	1096	3272
	3000	668	2105	734	2405	1130	3362	1288	3806	1331	3959	1388	4147
	3600	860	2710	946	3097	1457	4334	1660	4906	1716	5104	1790	5346
	4200	1002	3157	1101	3608	1695	5043	1932	5709	1997	5940	2083	6221
4800	1137	3585	1251	4096	1925	5729	2194	6486	2269	6747	2365	7067	

75/65/20 °C → 75°C inlet temperature, 65°C outlet temp., 20 °C room temp. / **Output 90/70/20 °C** = ~ 1,22 x 75/65/20 °C / **Output 70/55/20 °C** = ~ 0,84 x 75/65/20 °C / Heating outputs in accordance with EN442 / Not listed heating outputs for lengths per 100 mm steps calculate linearly.

Lengths (mm)		SPEED [-] / ACOUSTIC PRESSURE [dB(A)]											
		250/65		250/80		250/90		250/110		250/125		250/140	
		min	max	min	max	min	max	min	max	min	max	min	max
Lengths (mm)	700	20	29	20	29	20	37	20	37	20	37	20	37
	900	20	30	20	30	20	38	20	38	20	38	20	38
	1200	20	31	20	31	20	39	20	39	20	39	20	39
	1500	20	33	20	33	20	40	20	40	20	40	20	40
	1800	20	34	20	34	20	41	20	41	20	41	20	41
	2100	20	35	20	35	20	42	20	42	20	42	20	42
	2400	20	35	20	35	21	43	21	43	21	43	21	43
	3000	20	36	20	36	22	44	22	44	22	44	22	44
	3600	20	37	20	37	24	45	24	45	24	45	24	45
	4200	20	38	20	38	25	46	25	46	25	46	25	46
4800	20	38	20	38	26	47	26	47	26	47	26	47	

Acoustic pressure level choose according to specific environment.

Lengths (mm)		Speed [-] / Fans input power [W]											
		250/65		250/80		250/90		250/110		250/125		250/140	
		min	max	min	max	min	max	min	max	min	max	min	max
Lengths (mm)	700	1	2	1	2	1	3	1	3	1	3	1	3
	900	1	2	1	2	2	5	2	5	2	5	2	5
	1200	2	4	2	4	3	8	3	8	3	8	3	8
	1500	3	5	3	5	4	10	4	10	4	10	4	10
	1800	3	5	3	5	5	12	5	12	5	12	5	12
	2100	4	7	4	7	5	14	5	14	5	14	5	14
	2400	4	7	4	7	6	16	6	16	6	16	6	16
	3000	5	9	5	9	8	20	8	20	8	20	8	20
	3600	7	12	7	12	9	25	9	25	9	25	9	25
	4200	7	13	7	13	11	28	11	28	11	28	11	28
4800	8	15	8	15	12	33	12	33	12	33	12	33	

Approximate fan input powers / When using electrothermal actuator add in the trench heater's power 3 W

## GENERAL

Fan speeds show max and min of 4 setting speeds