

**DECLARATION OF INCORPORATION AND INFORMATION FOR SAFE INSTALLATION, OPERATION AND MAINTENANCE**

We declare that the machinery named below is intended to be assembled with other components to constitute a system of machinery. All parts except for moving parts requiring the correct installation of safety guards comply with the essential requirements of the Machinery Directive. The machinery shall not be put into service until the system has been declared to be in conformity with the provisions of the EC Machinery Directive.

Signature of manufacture representatives:		
Name:	Position:	Date:
1) S. Price	Managing Director	01. 11. 11
2) I. Brown	Production Managar	01. 11. 11

Designation of machinery: Destratair  
 Machinery Types: AX Axial Flow Fan  
 Relevant EC Council Directives: 2006/42/EC (Machinery Directive)  
 Applied National Standards: BS848 Parts 1, 2.2 and 5

Note: All standards used were current and valid at the date of signature.

**INFORMATION FOR SAFE INSTALLATION, OPERATION AND MAINTENANCE OF PRICE TWA VENTILATION EQUIPMENT**

To comply with EC Council Directives 98/37/EC Machinery Directive and 2004/108/EC (EMC).

To be read in conjunction with the relevant Product Documentation (see 2.1)

**1.0 GENERAL**

1.1 The equipment referred to in this Declaration of Incorporation is supplied by Price Twa to be assembled into a ventilation system which may or may not include additional components.

The entire system must be considered for safety purposes and it is the responsibility of the installer to ensure that all of the equipment is installed in compliance with the manufacturers recommendations and with due regard to current legislation and codes of practice.

**2.0 INFORMATION SUPPLIED WITH THE EQUIPMENT**

2.1 Each item of equipment is supplied with a set of documentation which provides the information required for the safe installation and maintenance of the equipment. This may be in the form of a Data sheet and/or Installation and Maintenance instruction.

2.2 Each unit has a rating plate attached to its outer casing. The rating plate provides essential data relating to the equipment such as serial number, unit code and electrical data. Any further data that may be required will be found in the documentation. If any item is unclear or more information is required, contact Price Twa.

2.3 Where warning labels or notices are attached to the unit the instructions given must be adhered to.

**3.0 TRANSPORTATION, HANDLING AND STORAGE**

3.1 Care must be taken at all times to prevent damage to the equipment. Note that shock to the unit may result in the balance of the impeller being affected.

3.2 When handling the equipment, care should be taken with corners and edges and that the weight distribution within the unit is considered. Lifting gear such as slings or ropes must be arranged so as not to bear on the casing.

3.3 Equipment stored on site prior to installation should be protected from the weather and steps taken to prevent ingress of contaminants.

**4.0 OPERATIONAL LIMITS**

4.1 It is important that the specified operational limits for the equipment are adhered to e.g. operational air temperature, air borne contaminants and unit orientation.

4.2 Where installation accessories are supplied with the specified equipment eg. wall mounting brackets. They are to be used to support the equipment only. Other system components must have separate provision for support.

4.3 Flanges and connection spigots are provided for the purpose of joining to duct work systems. They must not be used to support the ductwork.

**5.0 INSTALLATION REQUIREMENTS**

In addition to the particular requirements given for the individual product, the following general requirements should be noted.

5.1 Where access to any part of equipment which moves, or can become electrically live are not prevented by the equipment panels or by fixed installation detail (eg ducting), then guarding to the appropriate standard must be fitted.

5.2 The electrical installation of the equipment must comply with the requirements of the relevant local electrical safety regulations.

5.3 All control and sensor cables should not be placed within 50mm or on the same metal cable tray as 230V switched live, lighting or power cables and any cables not intended for use with this product.

**6.0 COMMISSIONING REQUIREMENTS**

6.1 General pre-commissioning checks relevant to safe operation consist of the following:

- Ensure that no foreign bodies are present within the fan or casing.
- Check electrical safety. e.g. Insulation and earthing.
- Check guarding of system.
- Check operation of Isolators/Controls.
- Check fastenings for security.

6.2 Other commissioning requirements are given in the relevant product documentation.

**7.0 OPERATIONAL REQUIREMENTS**

7.1 Equipment access panels must be in place at all times during operation of the unit, and must be secured with the original fastenings.

7.2 If failure of the equipment occurs or is suspected then it should be taken out of service until a competent person can effect repair or examination. (Note that certain ranges of equipment are designed to detect and compensate for fan failure).

**8.0 MAINTENANCE REQUIREMENTS**

8.1 Specific maintenance requirements are given in the relevant product documentation.

8.2 It is important that the correct tools are used for the various tasks required.

8.3 If the access panels are to be removed for any reason the electrical supply to the unit must be isolated.

8.4 A minium period of two minutes should be allowed after electrical disconnection before access panels are removed. This will allow the impeller to come to rest.

**NB: Care should still be taken however since airflow generated at some other point in the system can cause the impeller to "windmill" even when power is not present.**

8.5 Care should be taken when removing and storing access panels in windy conditions.



**DESTRATAIR**

**Installation and Maintenance**



CE The EMC Directive 2004/108/EC  
 The Low Voltage Directive 2006/95/EC

**Introduction**

Destratair can be integrated into any type of space heating system, old or new, to minimise air stratification and provide for total air distribution, without the use of ductwork.

System design utilising Destratair as the 'prime air mover' will reduce heat input requirements, generally maintain air stratification to within 1°C, and provide for comfortable working conditions throughout the building.

Destratair utilizes the total heat available however generated, and redistributes it counteracting the natural tendency of the hot air to rise to the underside of the roof.

- Destratair can be used with:
- oil, or gas-fired warm air heating systems
  - gas-fired radiant plaque heaters
  - overhead radiant tube and LTHW panel heaters
  - wet systems, gas-fired, oil-fired, and LTHW unit heaters
  - most types of electric radiant, plaque and warm air heaters

A range of sizes are available to suit most commercial and industrial applications (Single and Three phase).

**General Specification**

Unit consists of a high performance axial flow fan, housed within an aluzinc steel cabinet fitted with an aluminium alloy distribution grille.

Fan is directly driven by an electrical motor. Impeller has precision moulded, thermoplastic or aluminium aerofoil blades.

Fan plate manufactured in steel and shaped to provide optimum flow conditions at the fan outlet.

Unit to have integrated finger guards fitted to the inlet side. Motors have inbuilt thermal protection.

**Handling**

Before commencement of lifting ensure that normal equipment safety checks have been carried out and the lift/deposit areas are clear of site personnel and traffic.

Note: Weight of the unit is shown on the rating plate and should be lifted using the 4 lifting eyes provided.

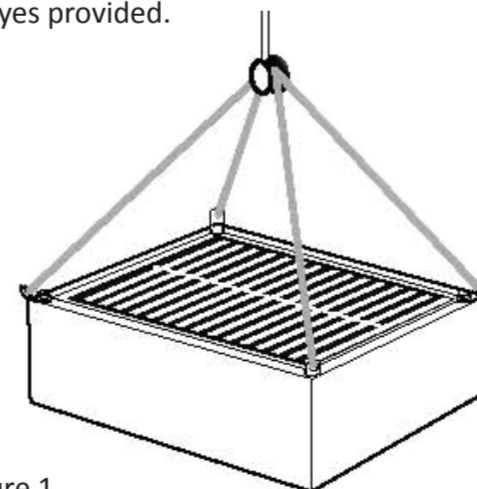

Figure 1

**Installation**

**IMPORTANT**

Installers - please note that Installation must be carried out by competent personnel in accordance with the appropriate authority and conforming to all statutory and governing regulations e.g. I.E.E, CIBSE, COHSE

For most installations, the units should be mounted at a height of 2.5 – 3.0m above floor level. Steel brackets or other suitable suspension arrangements (by others), should be used to secure each fan at the required height. Destratair should be set at an angle on the brackets to project air towards the roof of the building. (see figure 2 for typical mounting arrangement).

For taller buildings, or where wall space is taken for other purposes, the fans can be positioned higher. Please consult our technical team for advice.

When used together with any form of space heating system, Destratair fans should be electrically inter-locked with the heating control to provide continuous operation during the heating period. A means of electrical isolation should be provided (by others) to each fan to isolate the units during maintenance procedures.

To control noise emission, where necessary, auto-trans-former speed controllers should be used.

System commissioning services are available via a specialist contractor. Please ask for details.

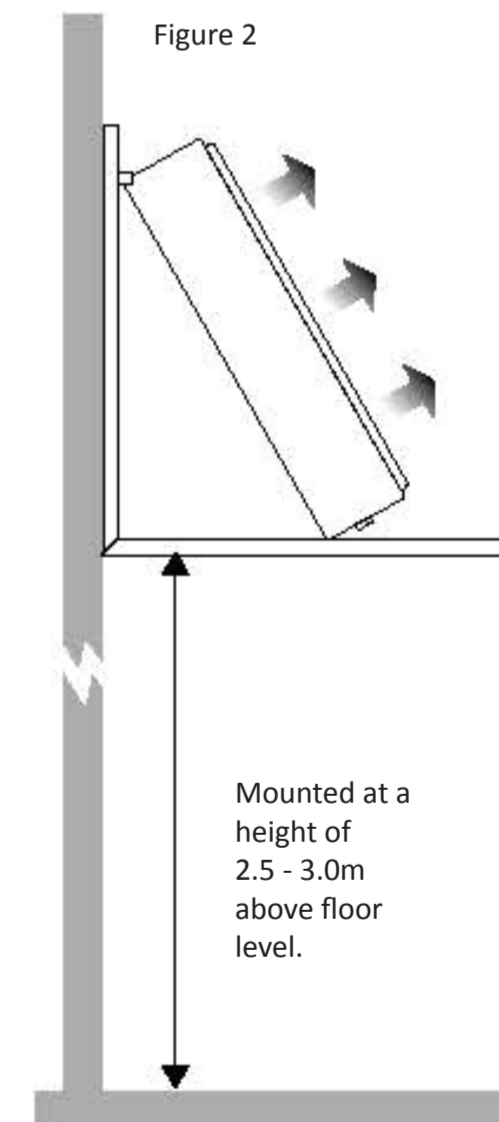

Figure 2

Mounted at a height of 2.5 - 3.0m above floor level.

**Price Twa**

Units 1 & 2 Smiths Forge Industrial Estate, North End Road, Yatton, North Somerset, BS49 4AU.  
 Tel: +44 (0)1934 835900 - Fax: +44 (0)1934 832835 - Email: sales@pricetwa.co.uk - Web: www.pricetwa.co.uk

Unit dimensions (mm) and weights (kg)

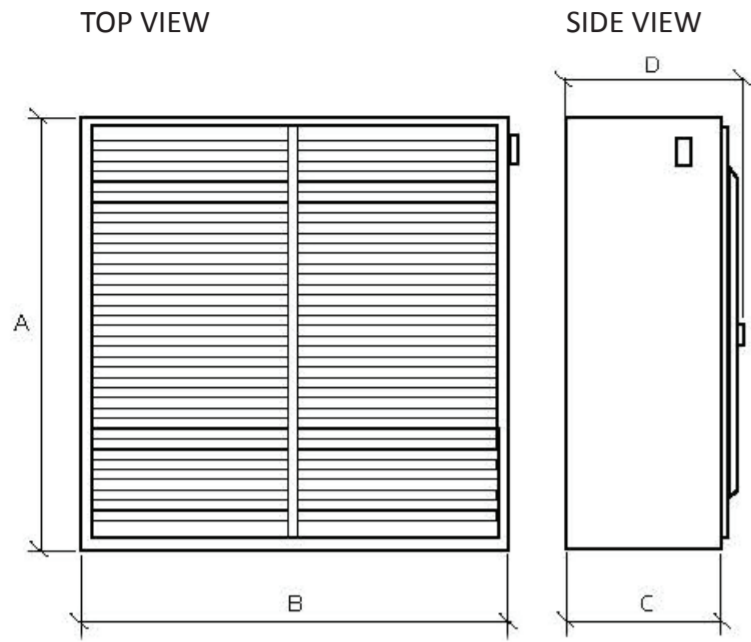

Unit Code	A	B	C	D	Weight (kg)	Speed Controller***
Destratair A/1	500	500	230	254	23	DE-SPCON1.5
Destratair 1/1	740	740	240	335	35	DE-SPCON3.5
Destratair 1/3	740	740	240	335	35	DE-SPCON4.0
Destratair 2/1	820	820	270	350	40	DE-SPCON3.5
Destratair 2/3	820	820	270	350	40	DE-SPCON4.0
Destratair 3/1	918	918	315	415	58	DE-SPCON7.5
Destratair 3/3	918	918	315	415	58	DE-SPCON4.0
Destratair 4/3	990	990	315	315	95	DE-PT10*

\* This model uses a variable potentiometer for speed control of unit.  
 \*\*\* All other fans use 'auto-transformer 5-setting type' speed controllers.

Electrical Details

Units are not supplied with electrical isolators, their selection and provision is the responsibility of the installer.

Ensure that the electrical supply is suitable for the fan and that all wiring, fuse and overload protection etc is appropriately sized by comparing with the rating plate.

Electrical connection is made direct to the motor termination box on all fans (See figure 3).

Where transformer speed controls are used please see relevant control connection diagram (See figure 4).

IMPORTANT

**Isolation - Before commencing work make sure that the unit, and controller are electrically isolated from the mains supply.**

**Please note this product must be earthed.**

**For good EMC engineering practice, any sensor cables or switched live cables should not be placed within 50mm of other cables or on the same metal cable tray as other cables.**

Figure 3. SINGLE PHASE (1ph)

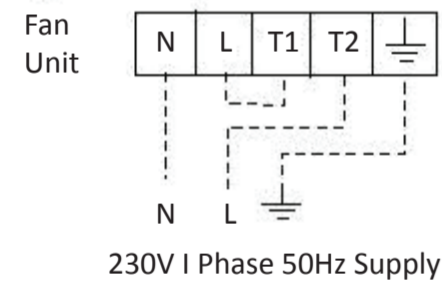

Note: If starter control fitted, failure to connect Thermal Protection T1 or T2 as shown will invalidate warranty.

THREE PHASE (3ph)

(Interchange any two fan supply phases to reverse rotation)

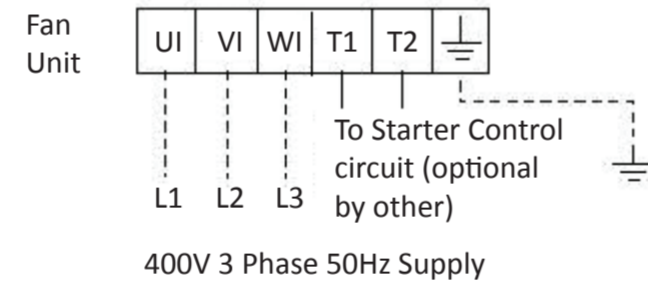

Note: If starter control fitted, failure to connect Thermal Protection T1 or T2 as shown will invalidate warranty.

Figure 4. CONTROLLER CONNECTIONS SINGLE PHASE (1ph)

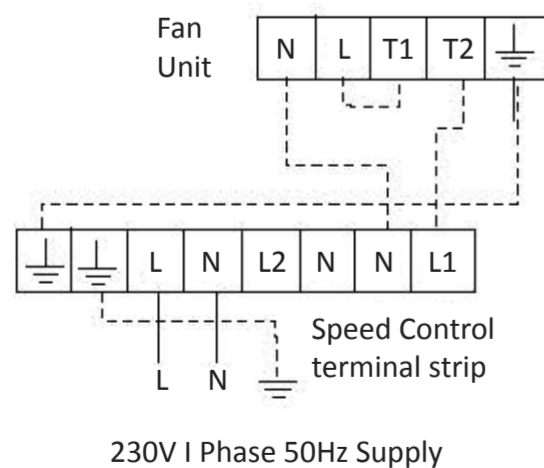

Note: If starter control fitted, failure to connect Thermal Protection T1 or T2 as shown will invalidate warranty.

CONTROLLER CONNECTIONS THREE PHASE (3ph)

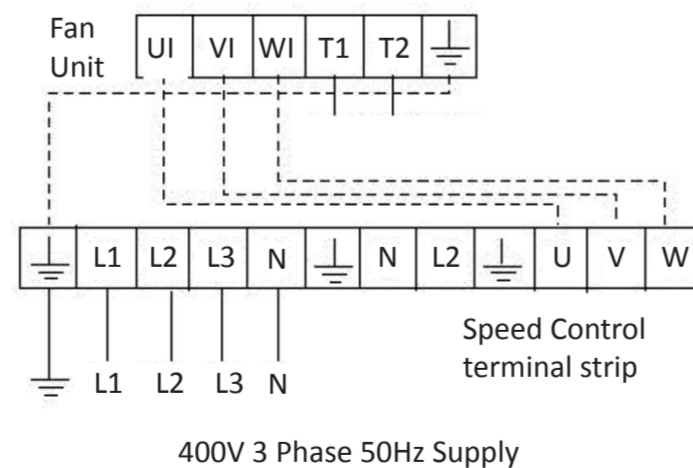

Note: If starter control fitted, failure to connect Thermal Protection T1 or T2 as shown will invalidate warranty.

IMPORTANT

**Isolation - Before commencing work make sure that the unit, and control are electrically isolated from the mains supply.**

**Please note this product must be earthed.**

Maintenance Intervals

The first maintenance should be carried out three months after commissioning and there after at twelve monthly intervals. These intervals may need to be shortened if the unit is operating in adverse environmental conditions, or in heavily polluted air.

Lubrication

Motors are fitted with sealed for life bearings and do not require any lubrication.

General Cleaning and Inspection

Clean and inspect the exterior of the fan unit and associated controls etc.

Inspect and, if necessary, clean the fan impeller and motor assemblies and the interior of the case.

Check all parts for security and condition.  
 Check that the impeller rotates freely.  
 Ensure all control components are secure and clean, replace all access doors.

Replacement of Parts

Should any component need replacing, Price Twa keep extensive stocks for quick delivery. Ensure that the unit is electrically isolated, before carrying out any work.

When ordering spare parts, please quote the serial number of the unit and the project number of the purchase if possible.

**(This information will be available on the fan label).**

3 Year Warranty

The 3 year warranty starts from the day of delivery and includes parts and labour for the first year. The remaining 2 years covers replacement parts only.

**This warranty is conditional on planned maintenance being undertaken.**

Service Enquiries

Price Twa can help you in all aspects of service. Our service department will be happy to provide any assistance required, initially by telephone and if necessary arrange for an engineer to call within 48 hours if possible.

**Tel: 01934 835900**  
**Fax: 01934 832835**

**Technical or commercial considerations may, from time to time, make it necessary to alter the design, performance and dimensions of equipment and the right is reserved to make such changes without prior notice.**